

REVISION HISTORY		
REV	DESCRIPTION	DATE
1	.51 CSK WAS .43	8/4/2021
2	ADDED BAIL 4" SCREW WAS 3.75" LOCK NUT CAHNGED TO THIN 0.775" OD WASHER WAS 0.625" 0.075" THK WASHER WAS 0.060"	1/9/2025

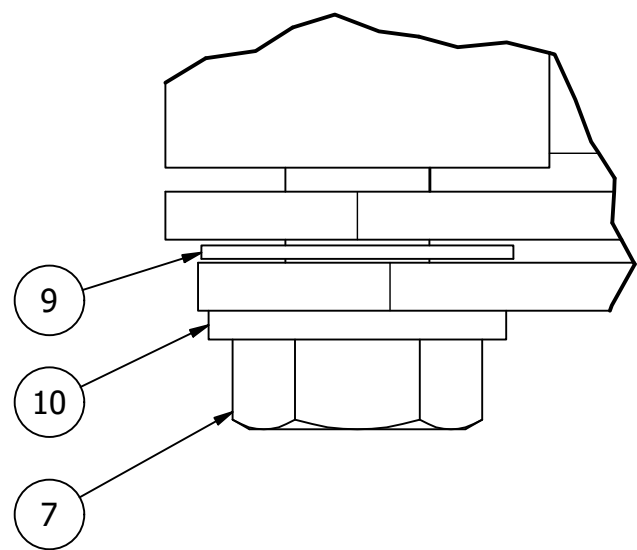

DETAIL A  
SCALE 2 : 1

PARTS LIST			
ITEM	QTY	PART NUMBER	DESCRIPTION
1	1		BASE
2	1		BAIL
3	1		ARTICULATING CHUTE
4	1	7551U-B	1" D X 2-7/8" W X 3/8"
5	1	7551U-A	2-3/8" D X 2-7/8" W X 3/8"
6	1		SCREW 3_8-16 X 4 HEX HEAD
7	1		SCREW 3/8-16 X 4.25 HEX HEAD
8	2		LOCK NUT 3_8-16 NYLON INSERT THIN
9	2		WASHER 0.380 ID X 0.812 OD X .035 THK PTFE
10	4		WASHER 0.390 ID X 0.775 OD X .075 THK SS

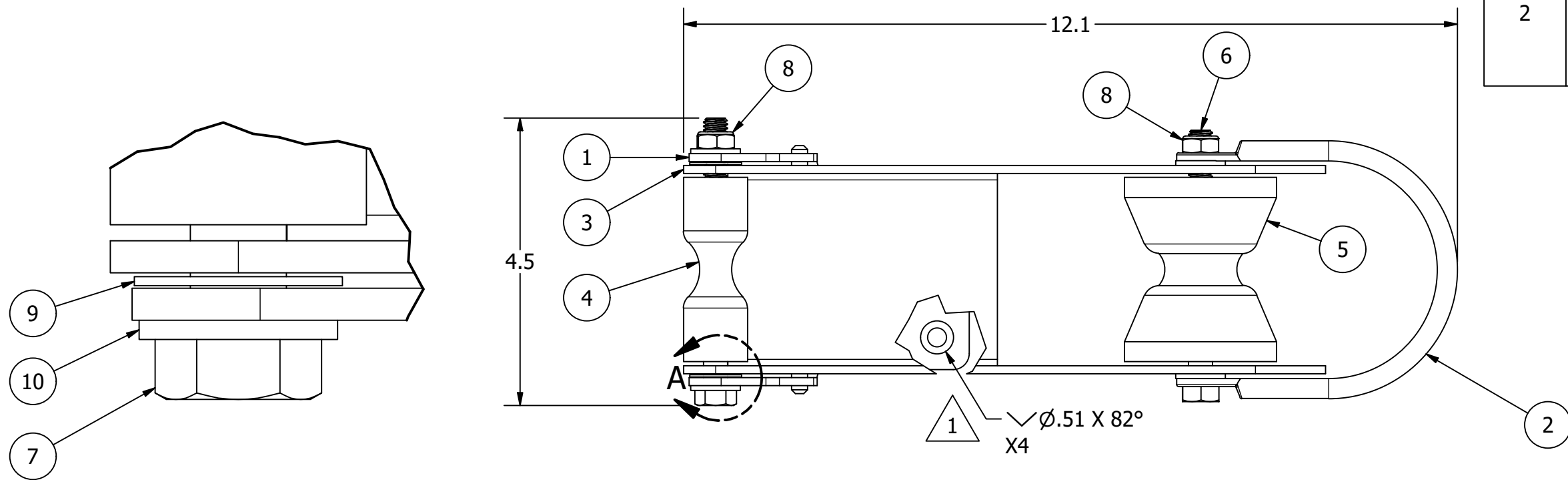
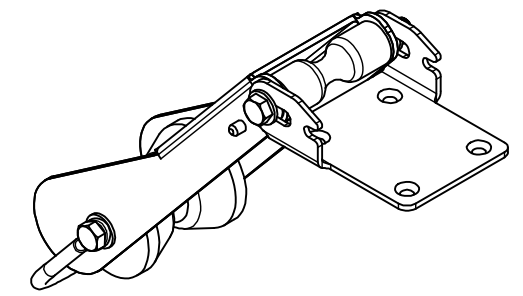
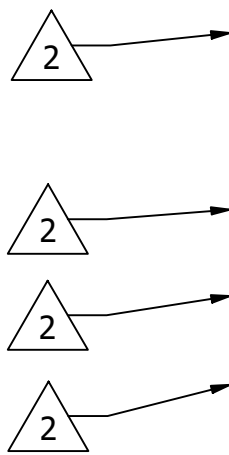

STOWED POSITION  
SCALE 1 : 4

UNLESS OTHERWISE SPECIFIED:  
BREAK ALL SHARP EDGES  
DIMENSIONS ARE IN INCHES  
TOLERANCES:  
FRACTIONAL: ± 1/16  
DECIMAL: X.X ± .05  
          X.XX ± .01  
          X.XXX ± .005  
ANGULAR: ± 1°  
FINISH: 120Ra

**PROPRIETARY AND CONFIDENTIAL**  
THE INFORMATION CONTAINED IN THIS  
DRAWING IS THE SOLE PROPERTY OF WHITE  
WATER MARINE HARDWARE. ANY REPRODUCTION  
IN PART OR AS A WHOLE WITHOUT WRITTEN  
PERMISSION IS PROHIBITED.

 <b>WHITE WATER</b> MARINE HARDWARE		TITLE	
		FOLDING ANCHOR ROLLER PART NUMBER: HD140097	
SIZE <b>B</b>	DRAWING NO. WWMH-HD140097	REV <b>2</b>	
SCALE 1 / 2	DRAWN KSR	DATE 8/4/2021	SHEET 1 OF 1