

NOTES:

1. MATERIAL: 316SS
2. FINISH: HIGH POLISH
3. PREVIOUSLY PN:2401SS

REVISION HISTORY		
REV	DESCRIPTION	DATE
1	3LB HOLD WAS 4LB	10/22/25

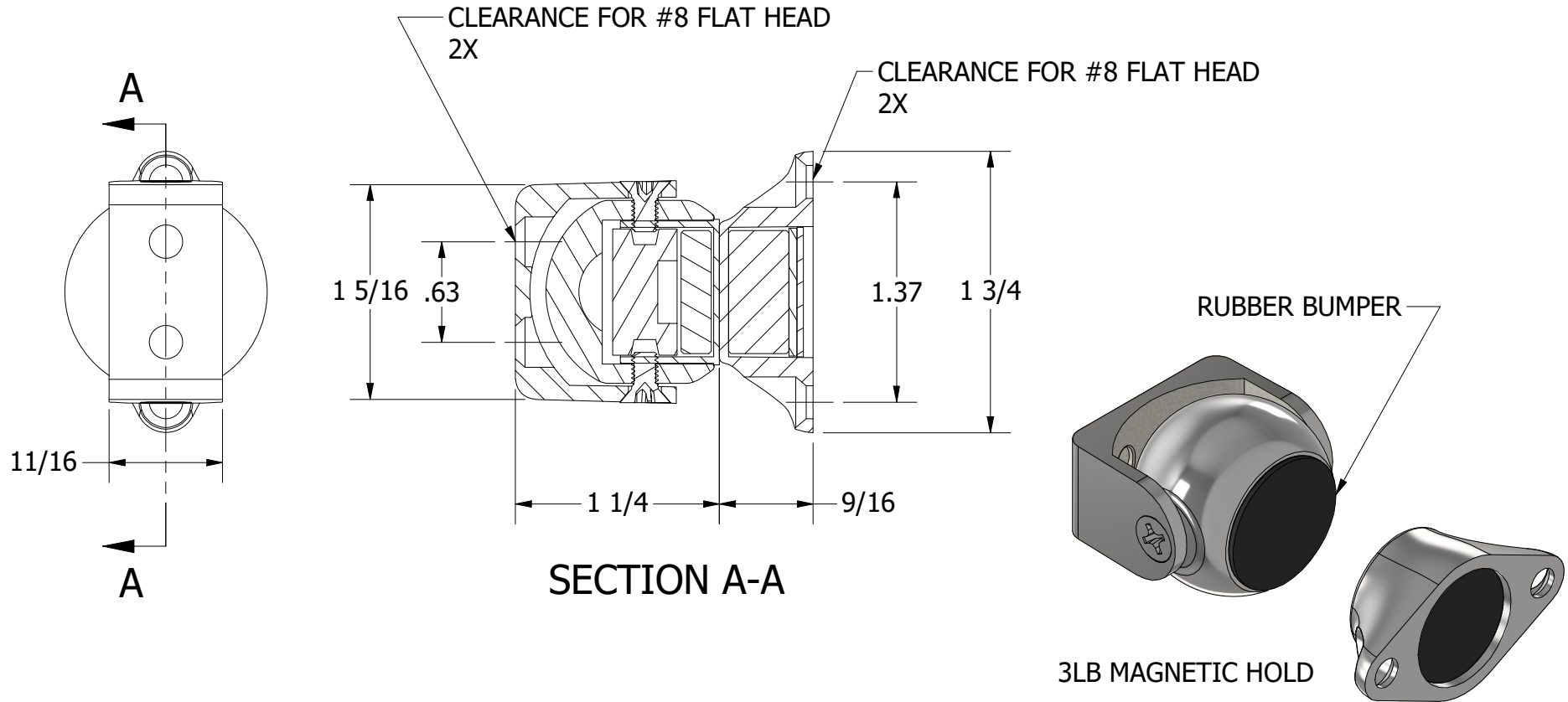

UNLESS OTHERWISE SPECIFIED:
 BREAK ALL SHARP EDGES
 DIMENSIONS ARE IN INCHES
 TOLERANCES:
 FRACTIONAL: $\pm 1/16$
 DECIMAL: X.X $\pm .05$
 X.XX $\pm .03$
 X.XXX $\pm .010$
 ANGULAR: $\pm 3^\circ$
 FINISH: 120Ra

PROPRIETARY AND CONFIDENTIAL
 THE INFORMATION CONTAINED IN THIS
 DRAWING IS THE SOLE PROPERTY OF WHITE
 WATER MARINE HARDWARE. ANY REPRODUCTION
 IN PART OR AS A WHOLE WITHOUT WRITTEN
 PERMISSION IS PROHIBITED.



WHITE WATER
 MARINE HARDWARE

TITLE			
PIVOTING MAGNETIC DOOR HOLDER			
PART NUMBER: 2420SS			
SIZE	DRAWING NO.		REV
A	WWMH-2420SS		1
SCALE	DRAWN	DATE	SHEET 1 OF 1
1 : 1	KSR	7/27/2021	