

FOR REFERENCE ONLY

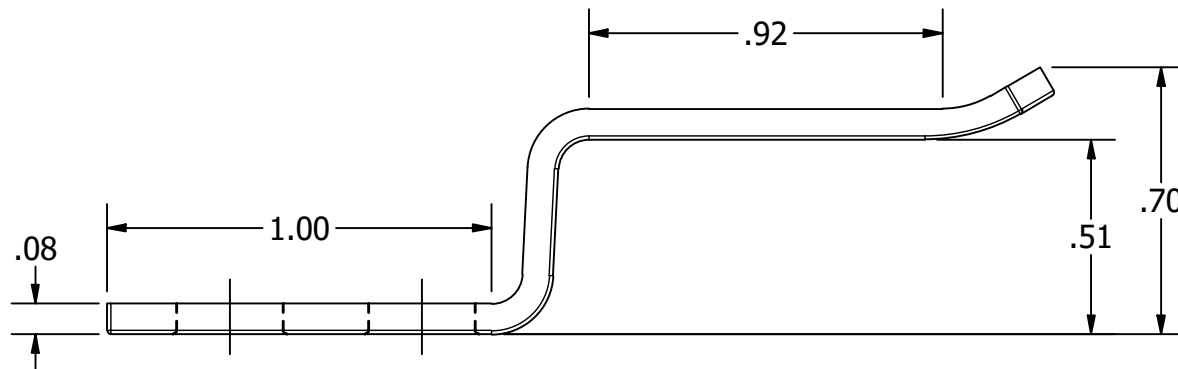

UNLESS OTHERWISE SPECIFIED:
 BREAK ALL SHARP EDGES
 DIMENSIONS ARE IN INCHES
 TOLERANCES:
 FRACTIONAL: $\pm 1/16$
 DECIMAL: X.X $\pm .05$
 X.XX $\pm .01$
 X.XXX $\pm .005$
 ANGULAR: $\pm 1^\circ$
 FINISH: 120Ra

PROPRIETARY AND CONFIDENTIAL
 THE INFORMATION CONTAINED IN THIS
 DRAWING IS THE SOLE PROPERTY OF WHITE
 WATER MARINE HARDWARE. ANY REPRODUCTION
 IN PART OR AS A WHOLE WITHOUT WRITTEN
 PERMISSION IS PROHIBITED.

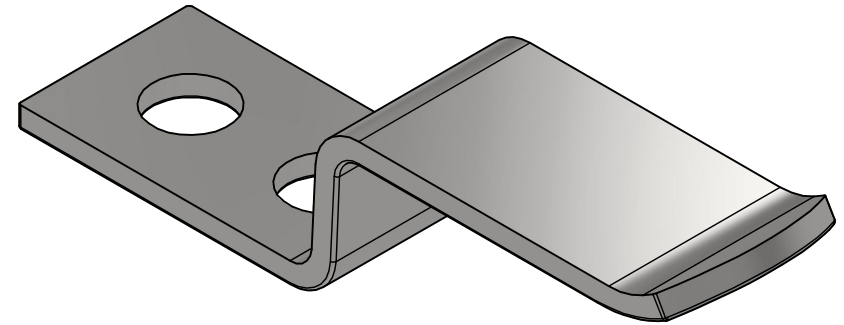
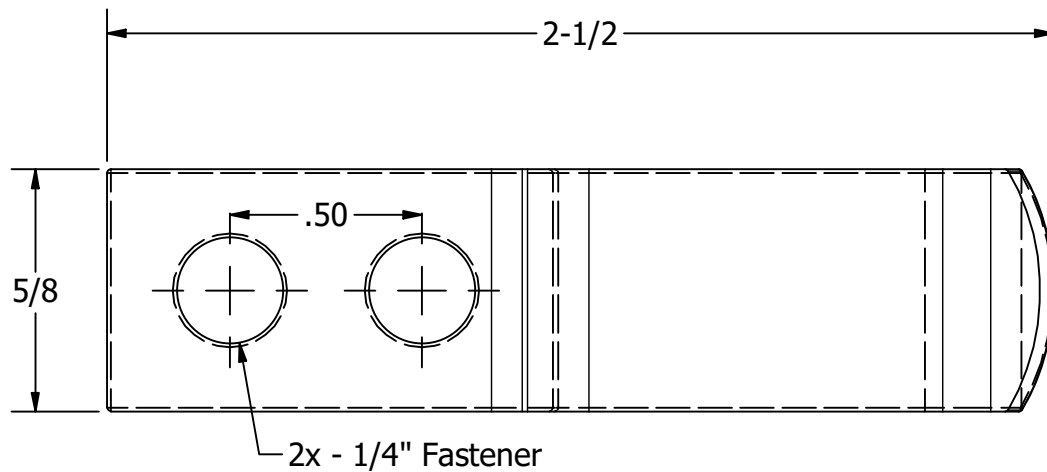

WHITE WATER
 MARINE HARDWARE

TITLE
 316 SS Upholstery Clip, 2-1/2 x 5/8"
 PART NUMBER: 50301S-316

SIZE A	DRAWING NO. WWMH-50301S-316 CC	REV 0
SCALE 2 : 1	DRAWN JVT	DATE 4/28/2023
		SHEET 1 OF 1