

NOTE  
316 STAINLESS STEEL CAST

FOR REFERENCE ONLY

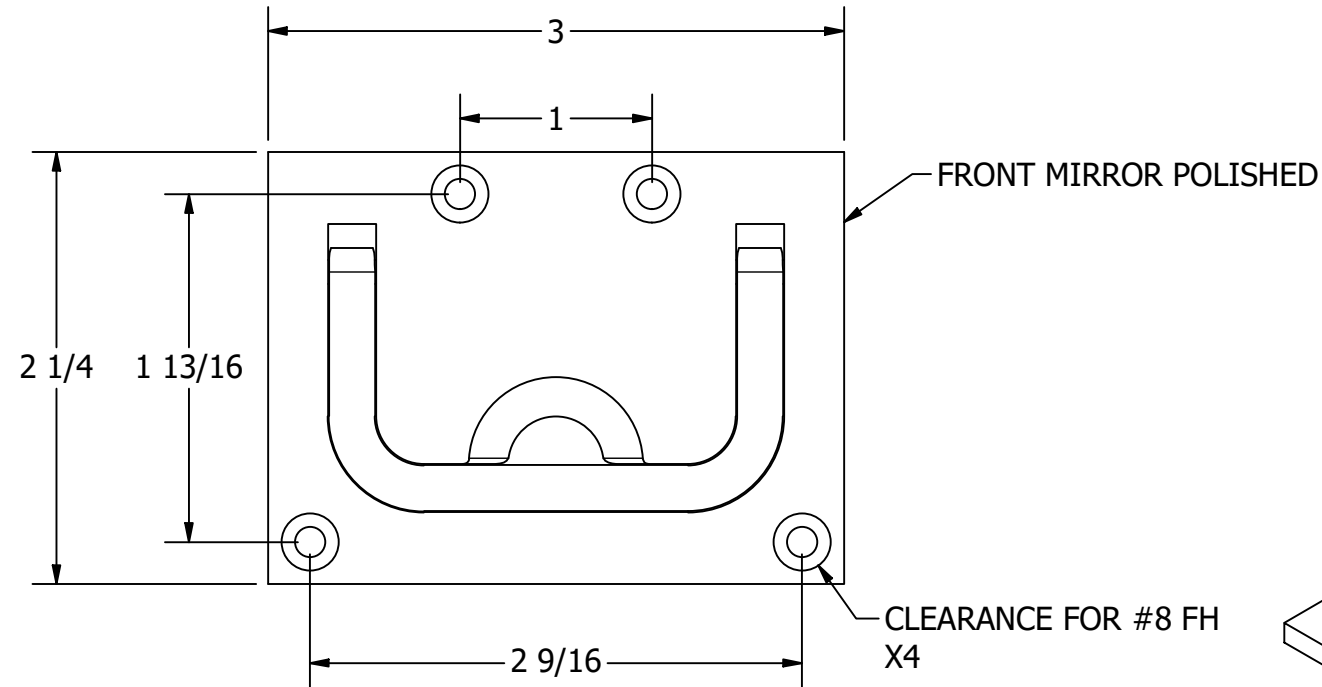

CLOSE POSITION  
SCALE 1 : 1

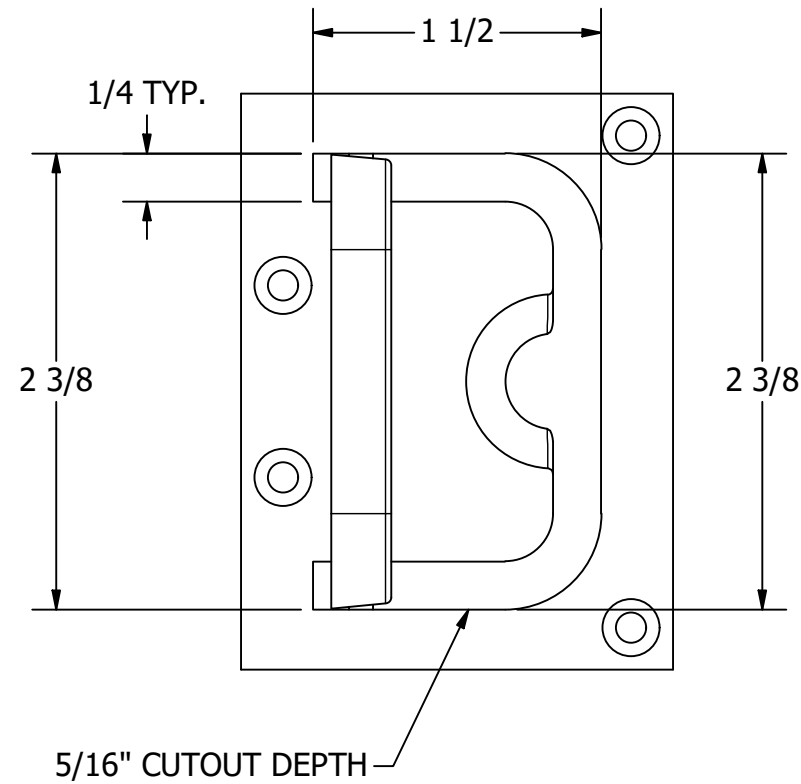
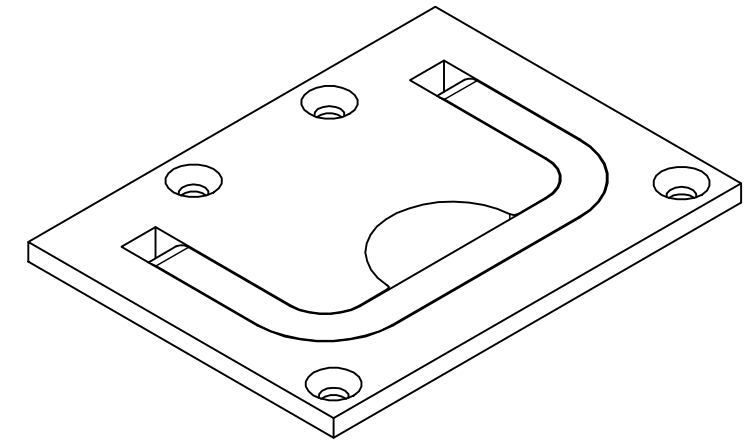

CLOSE POSITION  
SCALE 1 : 1

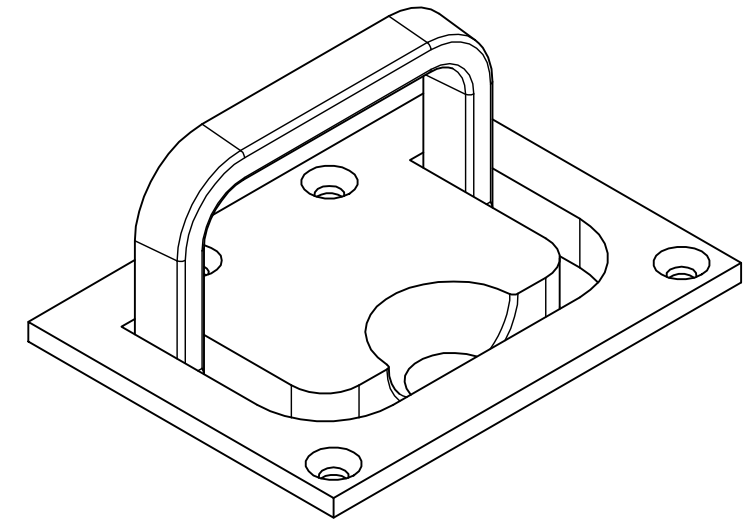

OPEN POSITION  
SCALE 1 : 1

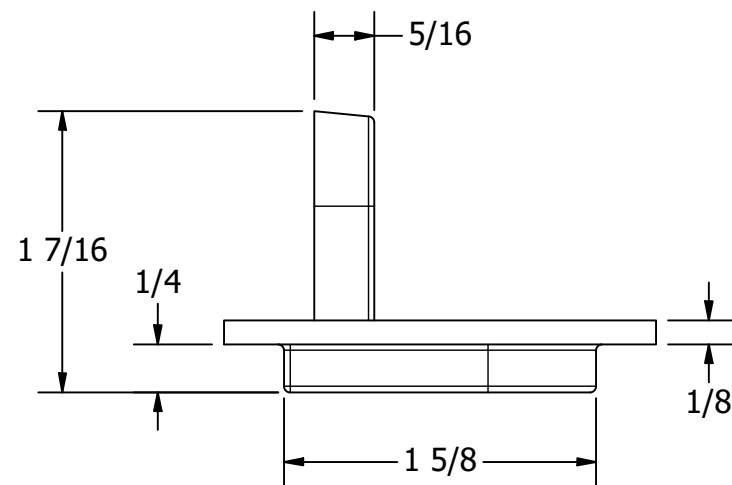

OPEN POSITION  
SCALE 1 : 1

UNLESS OTHERWISE SPECIFIED:  
BREAK ALL SHARP EDGES  
DIMENSIONS ARE IN INCHES  
TOLERANCES:  
FRACTIONAL:  $\pm 1/16$   
DECIMAL: X.X  $\pm .05$   
          X.XX  $\pm .01$   
          X.XXX  $\pm .005$   
ANGULAR:  $\pm 1^\circ$   
FINISH: 120Ra

**PROPRIETARY AND CONFIDENTIAL**  
THE INFORMATION CONTAINED IN THIS  
DRAWING IS THE SOLE PROPERTY OF WHITE  
WATER MARINE HARDWARE. ANY REPRODUCTION  
IN PART OR AS A WHOLE WITHOUT WRITTEN  
PERMISSION IS PROHIBITED.

		<b>WHITE WATER</b> MARINE HARDWARE	
		TITLE <b>FLUSH MOUNT LIFT HANDLE</b> PART NUMBER: 6094S	
SIZE <b>B</b>	DRAWING NO. WWMH-6094S	REV 0	
SCALE 1 : 1	DRAWN RC	DATE 2/18/2025	SHEET 1 OF 1