

# FOR REFERENCE ONLY

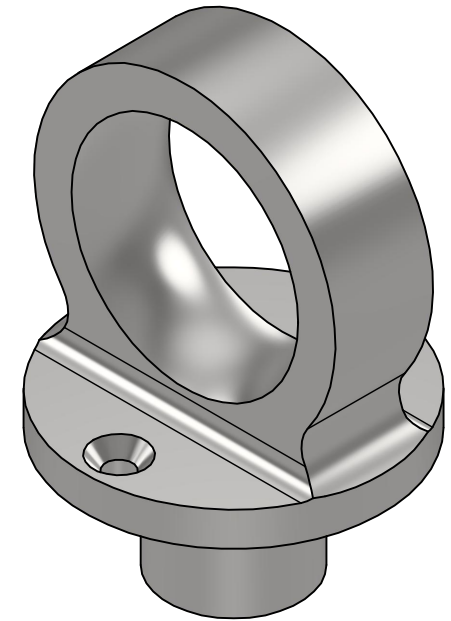

SECTION A-A  
SCALE 1 : 1

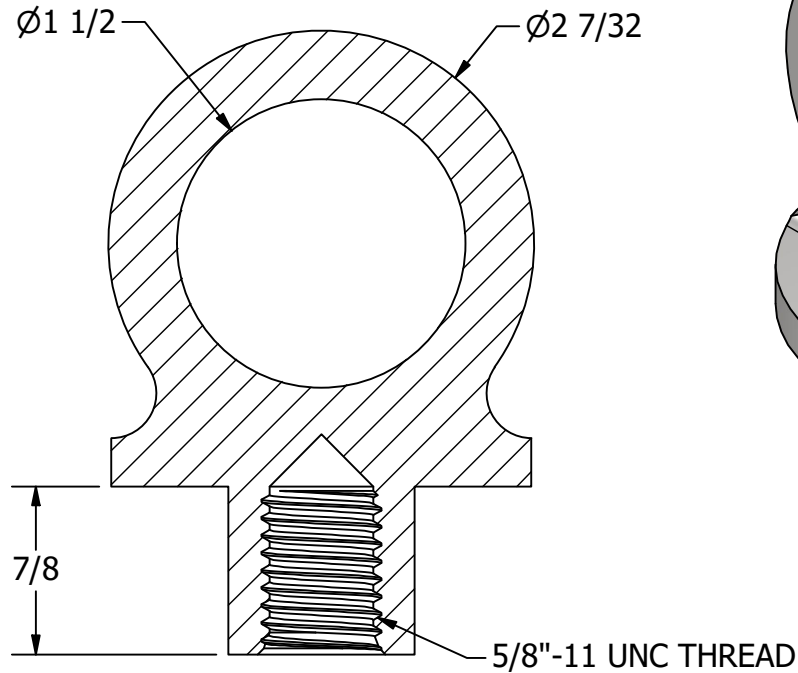
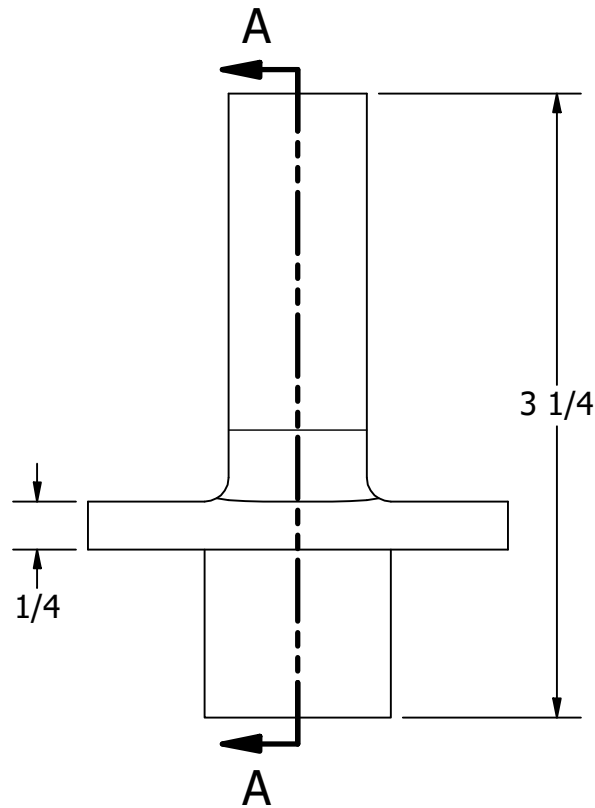
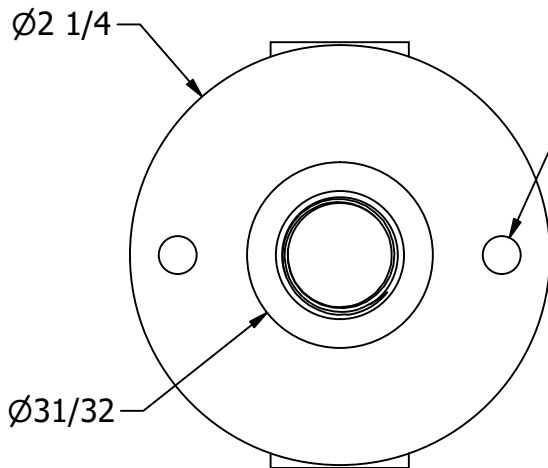

CLEARANCE FOR #10 FT SCREWS  
X2

UNLESS OTHERWISE SPECIFIED:  
BREAK ALL SHARP EDGES  
DIMENSIONS ARE IN INCHES  
TOLERANCES:  
FRACTIONAL:  $\pm 1/16$   
DECIMAL: X.X  $\pm .05$   
          X.XX  $\pm .01$   
          X.XXX  $\pm .005$   
ANGULAR:  $\pm 1^\circ$   
FINISH: 120Ra

**PROPRIETARY AND CONFIDENTIAL**  
THE INFORMATION CONTAINED IN THIS  
DRAWING IS THE SOLE PROPERTY OF WHITE  
WATER MARINE HARDWARE. ANY REPRODUCTION  
IN PART OR AS A WHOLE WITHOUT WRITTEN  
PERMISSION IS PROHIBITED.

		<b>WHITE WATER</b> MARINE HARDWARE	
		TITLE <b>STAINLESS BOAT LIFTING EYE</b> PART NUMBER: 6231S	
SIZE <b>A</b>	DRAWING NO. <b>WWMH-6231S</b>	REV <b>0</b>	
SCALE <b>1 : 1</b>	DRAWN <b>RC</b>	DATE <b>12/17/2024</b>	SHEET <b>1</b> OF <b>1</b>