

NOTES:

1. MATERIAL: 316SS
2. FINISH: MIRROR POLISH

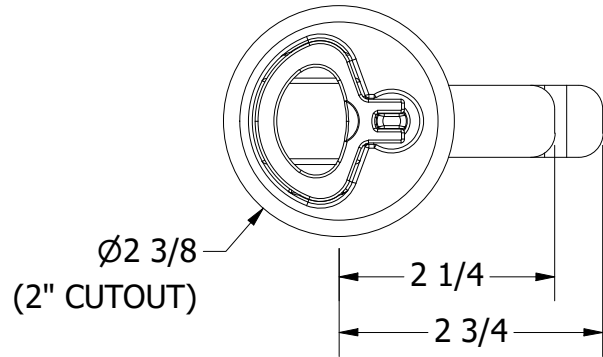

UNLATCHED POSITION
PAINTED RED

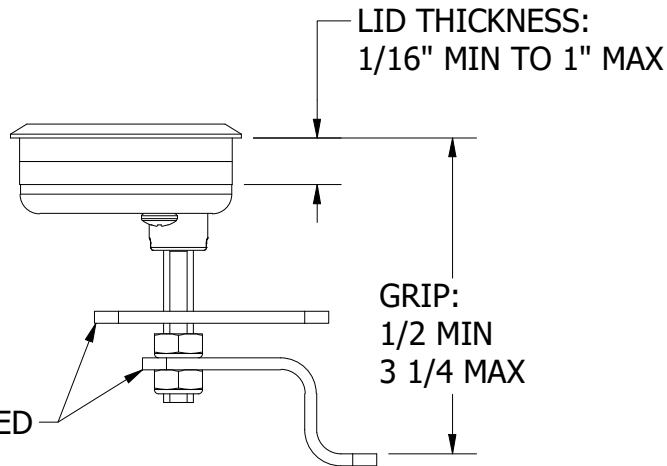
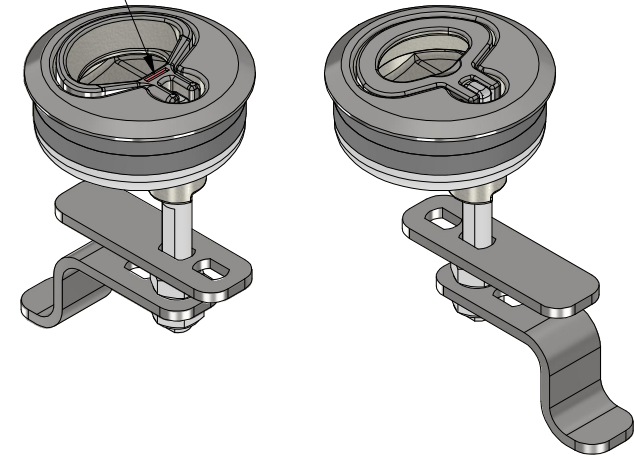

BOTH CAMS INCLUDED

REVISION HISTORY		
REV	DESCRIPTION	DATE
1	FILL VOID IN HANDLE RECESS, SHORTEN LIMIT PIN, ECN1037	6/16/25
2	WIDEN SHAFT AND REPLACE CAMS FROM 7155S, ECN1037	6/27/25
3	POLISH UNDERSIDE HANDLE, ADD RED INDICATOR, ECN1045	9/9/25
4	REDUCE HANDLE THICKNESS	9/18/25



WHITE WATER
MARINE HARDWARE

TITLE			
2" ROUND COMPRESSION LATCH PART NUMBER: 7154S			
SIZE	DRAWING NO.		REV
A	WWMH-7154S CC		4
SCALE	DRAWN	DATE	SHEET 1 OF 1
1 : 2	KSR	6/16/2025	

PROPRIETARY AND CONFIDENTIAL
THE INFORMATION CONTAINED IN THIS DRAWING IS THE SOLE PROPERTY OF WHITE WATER MARINE HARDWARE. ANY REPRODUCTION IN PART OR AS A WHOLE WITHOUT WRITTEN PERMISSION IS PROHIBITED.