

NOTE:
 1. SPRING FORCE 25-35 LBS IN STOWED POSITION.

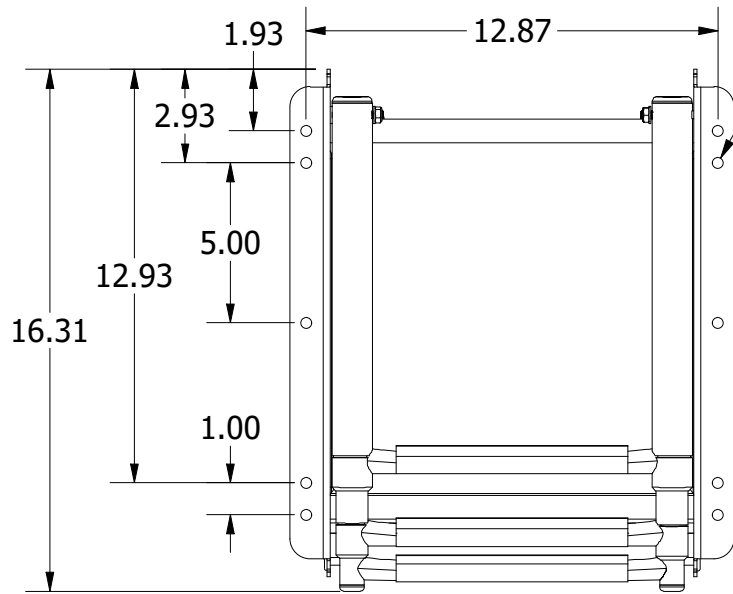

CLEARANCE FOR 5/16" FASTENER
 X10

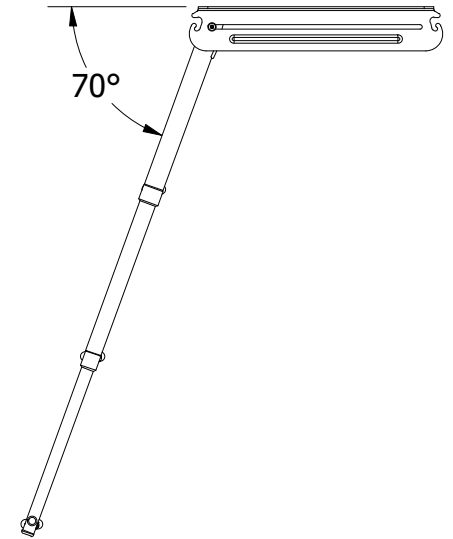
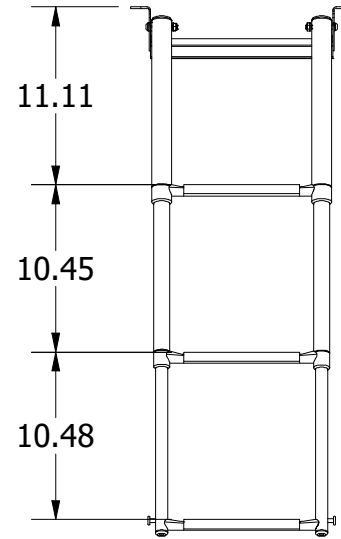

DEPLOYED VIEW
 SCALE 1 : 12

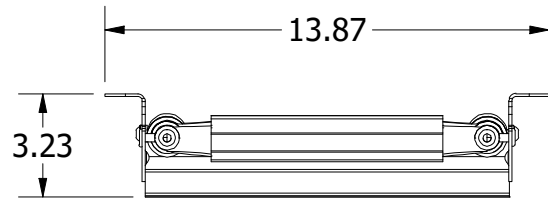

		WHITE WATER MARINE HARDWARE	
		TITLE UNDER PLATFORM LADDER PART NUMBER: B00301UHK-WH	
SIZE	DRAWING NO.	REV	
A	WWMH-B00301UHK-WH CC	0	
SCALE	DRAWN	DATE	SHEET 1 OF 1
1 : 6	KSR	8/16/2021	

PROPRIETARY AND CONFIDENTIAL
 THE INFORMATION CONTAINED IN THIS
 DRAWING IS THE SOLE PROPERTY OF WHITE
 WATER MARINE HARDWARE. ANY REPRODUCTION
 IN PART OR AS A WHOLE WITHOUT WRITTEN
 PERMISSION IS PROHIBITED.