

NOTES:

1. MATERIAL: 316SS
2. FINISH: HIGH POLISH
3. DO NOT ATTACH BOTTOM END OF TETHER.
TYPICALLY REMOVED DUE TO INTERFERENCE WITH PUMPOUT.

REVISION HISTORY		
REV	DESCRIPTION	DATE
1	.26 FLANGE WAS .20, ECN1073	4/13/26

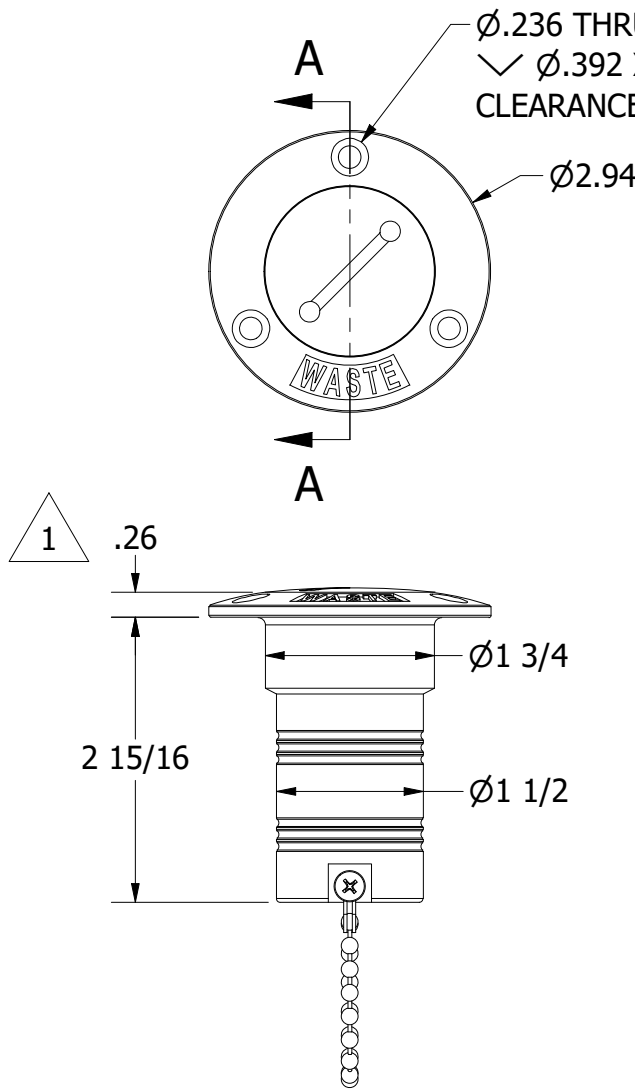

Ø.236 THRU
 ✓ Ø.392 X 82°
 CLEARANCE FOR #10 OVAL HEAD

Ø2.94

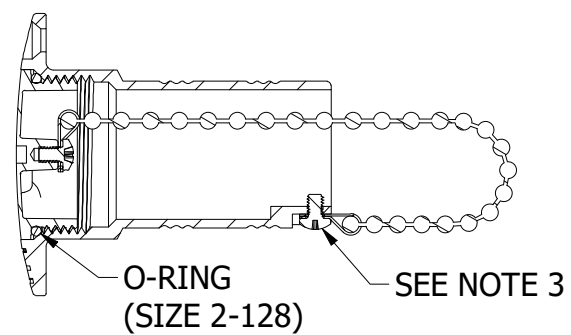

SECTION A-A

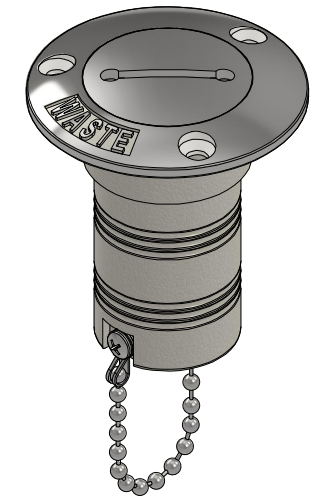
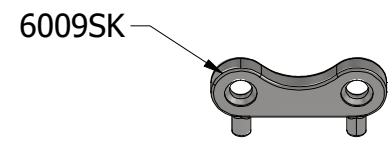

UNLESS OTHERWISE SPECIFIED:
 BREAK ALL SHARP EDGES
 DIMENSIONS ARE IN INCHES
 TOLERANCES:
 FRACTIONAL: ± 1/16
 DECIMAL: X.X ± .05
 X.XX ± .03
 X.XXX ± .010
 ANGULAR: ± 3°
 FINISH: 120Ra

PROPRIETARY AND CONFIDENTIAL
 THE INFORMATION CONTAINED IN THIS
 DRAWING IS THE SOLE PROPERTY OF WHITE
 WATER MARINE HARDWARE. ANY REPRODUCTION
 IN PART OR AS A WHOLE WITHOUT WRITTEN
 PERMISSION IS PROHIBITED.

		WHITE WATER MARINE HARDWARE	
		TITLE DECK FILL, WASTE PART NUMBER: 6002S	
SIZE A	DRAWING NO. WWMH-6002S		REV 1
SCALE 1 : 2	DRAWN KSR	DATE 4/13/2026	SHEET 1 OF 1