

NOTES
 316 STAINLESS STEEL
 HIGH POLISH FINISH

REVISION HISTORY		
REV	DESCRIPTION	DATE
1	.26 FLANGE WAS .20, ECN1073	4/13/26

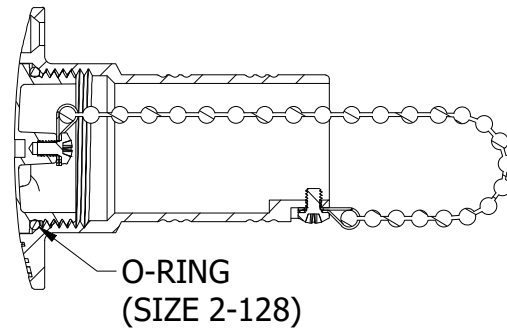

SECTION A-A

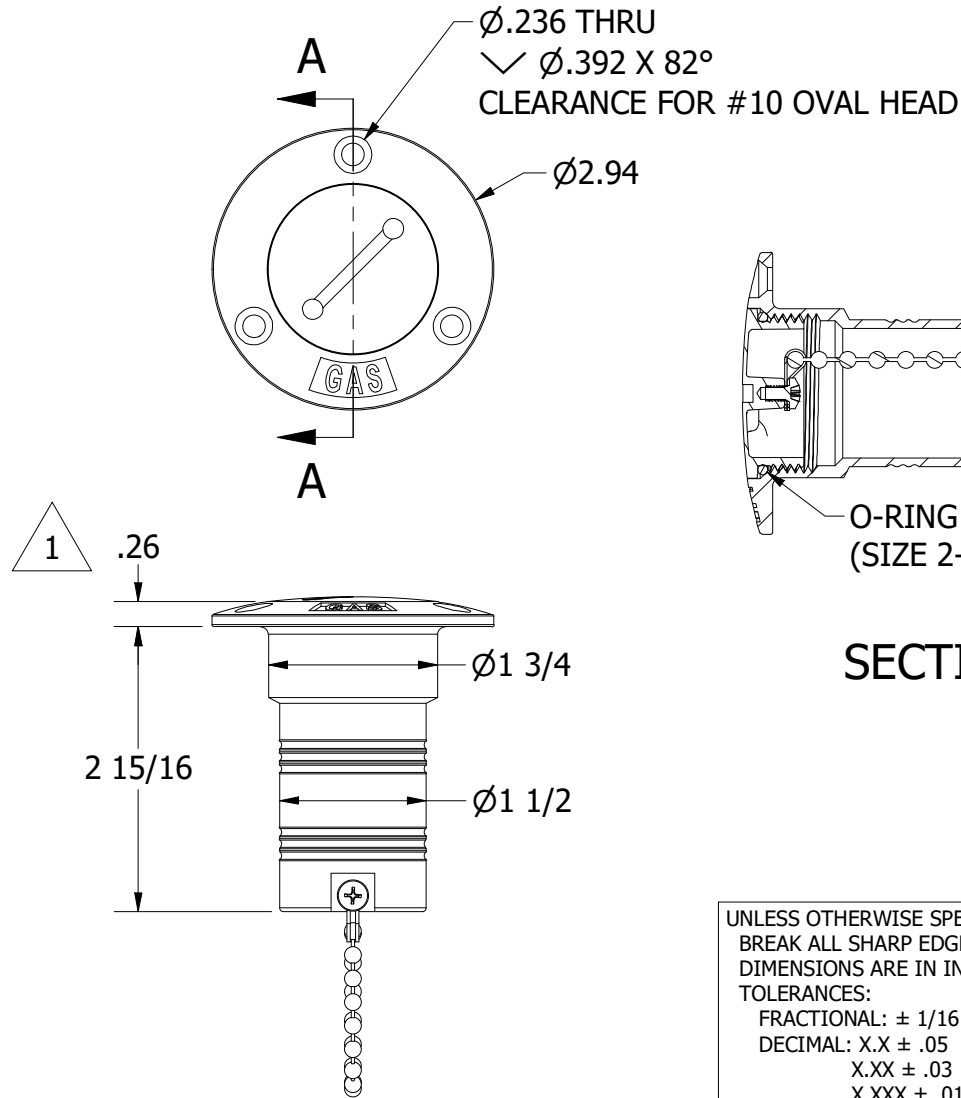
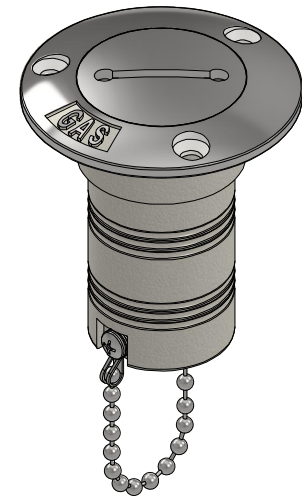
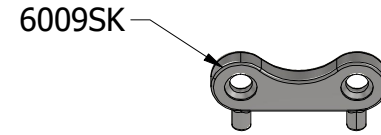

UNLESS OTHERWISE SPECIFIED:
 BREAK ALL SHARP EDGES
 DIMENSIONS ARE IN INCHES
 TOLERANCES:
 FRACTIONAL: $\pm 1/16$
 DECIMAL: X.X $\pm .05$
 X.XX $\pm .03$
 X.XXX $\pm .010$
 ANGULAR: $\pm 3^\circ$
 FINISH: 120Ra

PROPRIETARY AND CONFIDENTIAL
 THE INFORMATION CONTAINED IN THIS
 DRAWING IS THE SOLE PROPERTY OF WHITE
 WATER MARINE HARDWARE. ANY REPRODUCTION
 IN PART OR AS A WHOLE WITHOUT WRITTEN
 PERMISSION IS PROHIBITED.



WHITE WATER
 MARINE HARDWARE

TITLE			
DECK FILL, GAS			
PART NUMBER: 6005S			
SIZE	DRAWING NO.		REV
A	WWMH-6005S		1
SCALE	DRAWN	DATE	SHEET 1 OF 1
1 : 2	KSR	4/13/2026	