

NOTES:

1. MATERIAL: 316 SS
2. FINISH: HIGH POLISH

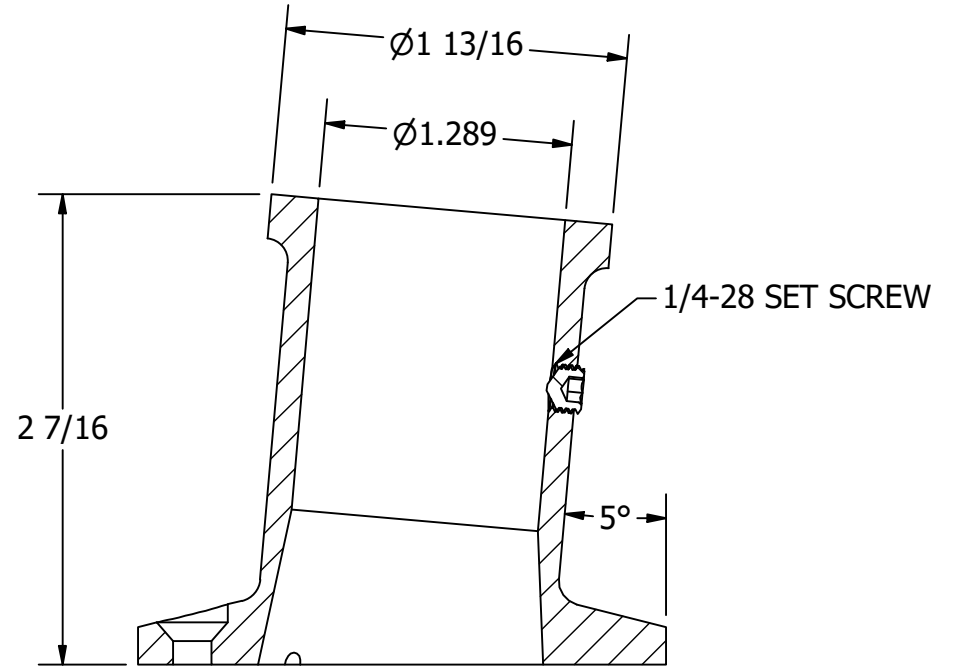

SECTION A-A

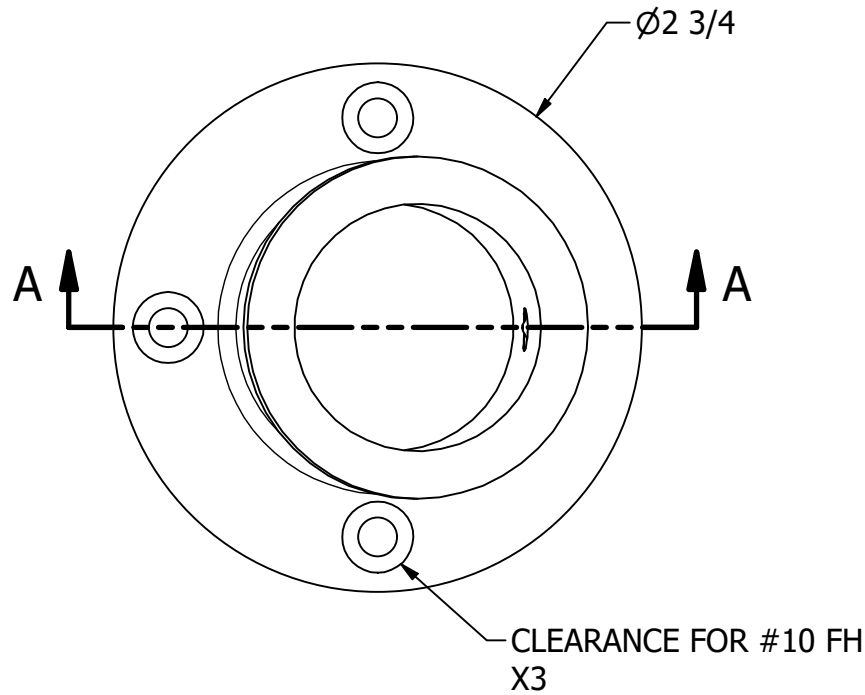
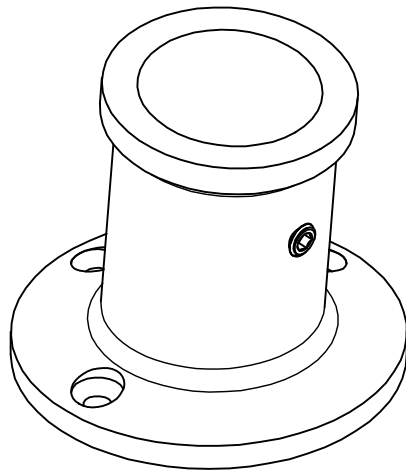

UNLESS OTHERWISE SPECIFIED:
 BREAK ALL SHARP EDGES
 DIMENSIONS ARE IN INCHES
 TOLERANCES:
 FRACTIONAL: ± 1/16
 DECIMAL: X.X ± .05
 X.XX ± .03
 X.XXX ± .010
 ANGULAR: ± 3°
 FINISH: 120Ra

PROPRIETARY AND CONFIDENTIAL
 THE INFORMATION CONTAINED IN THIS
 DRAWING IS THE SOLE PROPERTY OF WHITE
 WATER MARINE HARDWARE. ANY REPRODUCTION
 IN PART OR AS A WHOLE WITHOUT WRITTEN
 PERMISSION IS PROHIBITED.



WHITE WATER
 MARINE HARDWARE

TITLE
FLAGPOLE SOCKET TOP MOUNT
PART NUMBER: 6140S

SIZE A	DRAWING NO. WWMH-6140S	REV 0
SCALE 1 : 1	DRAWN RC	DATE 4/22/2026
		SHEET 1 OF 1