

NOTES:

1. MATERIAL: 316 SS
2. FINISH: HIGH POLISH

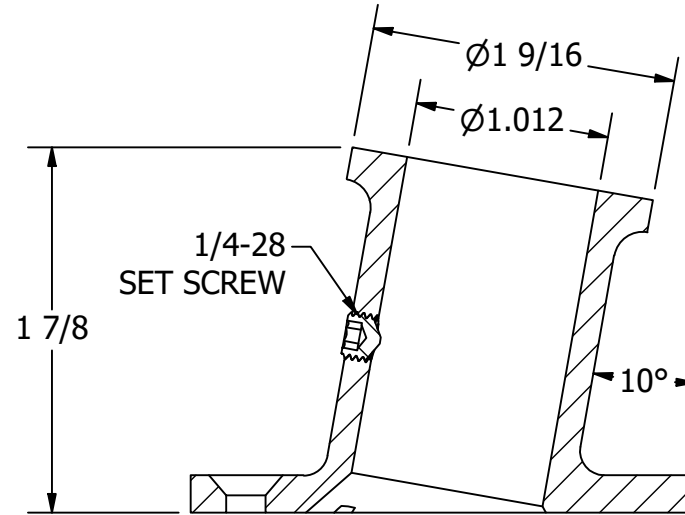
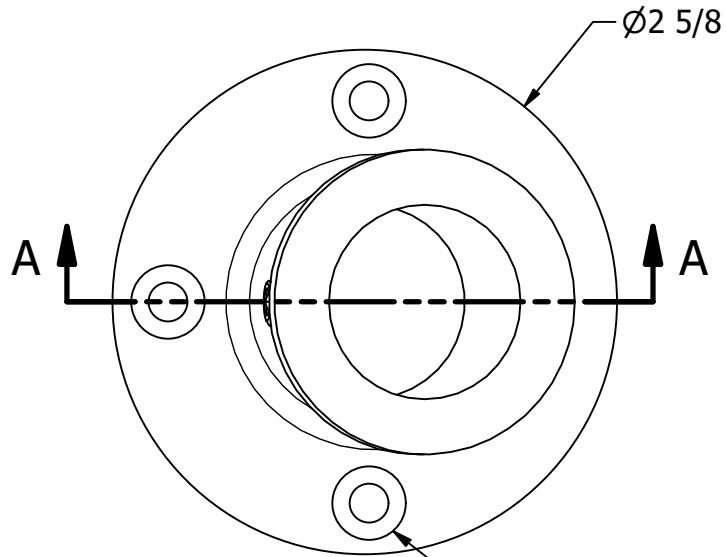

SECTION A-A

CLEARANCE FOR #10 FH
X3

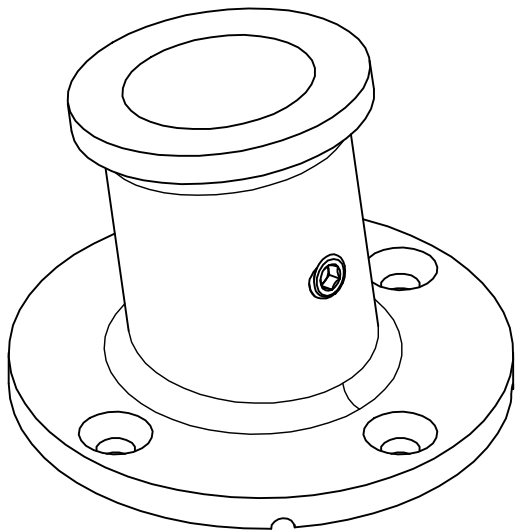

UNLESS OTHERWISE SPECIFIED:
BREAK ALL SHARP EDGES
DIMENSIONS ARE IN INCHES
TOLERANCES:
FRACTIONAL: $\pm 1/16$
DECIMAL: X.X $\pm .05$
 X.XX $\pm .03$
 X.XXX $\pm .010$
ANGULAR: $\pm 3^\circ$
FINISH: 120Ra

PROPRIETARY AND CONFIDENTIAL
THE INFORMATION CONTAINED IN THIS
DRAWING IS THE SOLE PROPERTY OF WHITE
WATER MARINE HARDWARE. ANY REPRODUCTION
IN PART OR AS A WHOLE WITHOUT WRITTEN
PERMISSION IS PROHIBITED.



WHITE WATER
MARINE HARDWARE

TITLE			
FLAGPOLE SOCKET TOP MOUNT PART NUMBER: 6141S			
SIZE	DRAWING NO.		REV
A	WWMH-6141S		0
SCALE	DRAWN	DATE	SHEET 1 OF 1
1 : 1	RC	4/22/2026	